



# INFORMATION BULLETIN 2006

The CSU requires you to take the English Placement Test (EPT) and the Entry Level Mathematics Test (ELM) prior to enrollment in the CSU unless you are exempt by means of scores earned on other appropriate tests such as the CSU's Early Assessment Program tests in English and Mathematics, the SAT, and the ACT. The EPT and the ELM are not admission tests; instead, they determine eligibility to enroll in specific courses. **If you are required to take the EPT and the ELM but fail to do so, you will not be allowed to register.** If you do not perform well on the tests, you will be placed in an appropriate remedial or developmental program or activity during your first term of enrollment.

Please read this Information Bulletin carefully to determine whether you may be exempt from either the EPT or the ELM. **If you are not exempt, you must take the tests prior to enrollment to avoid delaying your registration.** You may take the tests at the campus where you will enroll or at a CSU campus near you. There are many testing dates from which to choose. You should check with the campus to which you have been admitted to determine the date by which you are required to have taken the EPT/ELM. Some campuses may require students enrolling in the fall of 2006 to complete the tests by May 6, 2006; other campuses may allow you to take the tests in June, July, or August 2006, although putting the tests off this long may delay your timely enrollment process.

**See Pages 23 and 24 for Test Dates**

**INFORMATION BULLETIN IS AVAILABLE ON  
THE WEB AT <http://www.ets.org/csu/index.html>**

**The California State University  
English Placement Test (EPT) and  
Entry Level Mathematics (ELM) Examination**

## Table of Contents

<b>THE TESTS.....</b>	<b>3</b>
<b>PURPOSE OF THE EPT.....</b>	<b>3</b>
<b>WHO MUST TAKE THE EPT.....</b>	<b>3</b>
<b>PURPOSE OF THE ELM.....</b>	<b>3</b>
<b>WHO MUST TAKE THE ELM.....</b>	<b>3</b>
<b>WHERE THE TESTS WILL BE GIVEN.....</b>	<b>4</b>
<b>INQUIRIES ABOUT THE TESTS.....</b>	<b>4</b>
<b>EPT AND ELM REGISTRATION.....</b>	<b>4</b>
<b>Fees.....</b>	<b>4</b>
<b>Incomplete or Late Registrations.....</b>	<b>4</b>
<b>Walk-in Registration.....</b>	<b>4</b>
<b>Test Center Changes.....</b>	<b>5</b>
<b>Special Arrangements.....</b>	<b>5</b>
<b>Admission Tickets.....</b>	<b>5</b>
<b>TESTING SCHEDULE.....</b>	<b>5</b>
<b>WHAT TO BRING TO THE TEST CENTER.....</b>	<b>5</b>
<b>TEST ROOM REGULATIONS.....</b>	<b>5</b>
<b>CONFIDENTIALITY OF SCORES.....</b>	<b>6</b>
<b>SCORES ON THE EPT AND ELM.....</b>	<b>6</b>
<b>RELIABILITY.....</b>	<b>6</b>
<b>STANDARD ERROR OF MEASUREMENT.....</b>	<b>6</b>
<b>QUESTIONS AND ANSWERS ABOUT THE EPT.....</b>	<b>8</b>
<b>EPT TEST DESCRIPTION.....</b>	<b>9</b>
<b>What scores will you receive?.....</b>	<b>9</b>
<b>The Essay — 45 minutes.....</b>	<b>9</b>
<b>Reading Skills — 30 minutes.....</b>	<b>9</b>
<b>Composing Skills — 30 minutes.....</b>	<b>11</b>
<b>ENTRY LEVEL MATHEMATICS EXAMINATION.....</b>	<b>14</b>
<b>ELM TEST DESCRIPTION.....</b>	<b>14</b>
<b>TOPICS ON THE ELM TEST.....</b>	<b>15</b>
<b>CSU REGISTRATION AND TESTING CENTERS.....</b>	<b>22</b>
<b>TEST DATES.....</b>	<b>23</b>

## THE TESTS

The California State University systemwide placement testing program in basic reading, writing, and mathematics skills consists of the English Placement Test (EPT) and the Entry Level Mathematics (ELM) examination. Both tests are printed and scored for the CSU by Educational Testing Service (ETS). Please read the following information carefully.

**YOU MAY BE REQUIRED TO TAKE ONE OR BOTH OF THESE TESTS, REGARDLESS OF YOUR GPA.**

### PURPOSE OF THE EPT

The EPT is designed to assess the level of reading and writing skills of entering undergraduate students so that they can be placed in appropriate courses. Those undergraduate students who do not demonstrate college-level skills will be directed to courses or programs designed to help them attain these skills. The test is not a condition for admission to the CSU, but it is a condition of enrollment. **Students may take the EPT only once. It may not be repeated.** The fee for taking the EPT is \$18. The fee is nonrefundable and subject to change. In addition, some campuses may charge a nominal additional fee for some of the testing dates listed on pages 23 and 24 of this *Bulletin*. Please contact the test office at the campus where you plan to take the tests for information about this possible small fee.

### WHO MUST TAKE THE EPT

The CSU English Placement Test must be completed by all entering undergraduates, with the exception of those who present proof of one of the following:

- placement in the “exempt” category on the Early Assessment Program (EAP) English taken in conjunction with the 11<sup>th</sup> grade California Standards Test in English Language Arts
- a score of 550 or above on the verbal section of the College Board SAT I: Reasoning Test taken between April 1995 and January 2005
- a score of 550 or above on the critical reading section of the College Board SAT Reasoning Test taken March 2005 or later
- a score of 680 or above on the College Board SAT II: Writing Test taken between May 1998 and January 2005\*
- a score of 24 or above on the enhanced ACT English Test taken October 1989 or later
- a score of 3, 4, or 5 on either the Language and Composition or Literature and Composition examination of the College Board Advanced Placement Program
- completion and transfer to the CSU of a college course that satisfies CSU General Education requirement in English Composition, provided such a course was completed with a grade of C or better.

### PURPOSE OF THE ELM

The ELM examination is designed to assess the skill levels of entering CSU students in the areas of mathematics typically covered in three years of rigorous college preparatory mathematics courses in high school. Those undergraduate students who do not demonstrate college-level skills will be directed to courses or programs designed to help them attain these skills. The ELM is not a condition for admission to the CSU, but it is a condition of enrollment. It may be taken only **once** during each of the following time spans: (1) 1/15/06 – 2/18/06– inclusive; (2) 2/19/06 – 3/17/06 inclusive; (3) 3/19/06 – 5/5/06 inclusive; (4) 5/7/06 – 6/16/06 inclusive; (5) 6/18/06 – 10/21/06 inclusive; (6) 10/22/06 – 1/13/07 inclusive. The ELM may also be taken once on March 18, 2006; May 6, 2006; and June 17, 2006.

Cost to the student for taking the test is \$18. This fee is nonrefundable and subject to change. Some campuses charge a slightly higher ELM fee for some of the testing dates listed on the pages 23 and 24 of this Bulletin. Please contact the test office at the campus where you plan to take the tests for information about whether you will be charged a slightly higher fee.

### WHO MUST TAKE THE ELM

All entering undergraduates must take the ELM examination before enrolling in a course that satisfies the college-level mathematics requirement of the General Education-Breadth program. Exemptions from the test are given only to those students who can present proof of one of the following:

- placement in the “exempt” category on the Early Assessment Program (EAP) Mathematics taken in conjunction with the 11<sup>th</sup> grade California Standards Test in High School Mathematics or Algebra II
- placement in the “conditionally exempt” category on the Early Assessment Program (EAP) Mathematics taken in conjunction with the 11<sup>th</sup> grade California Standards Test in High School Mathematics or Algebra II PLUS successful completion of a CSU-approved math or math-related course or activity taken before you enroll at a CSU campus
- a score of 550 or above on the mathematics section of the College Board SAT Reasoning Test (previously known as the SAT I: Reasoning Test)
- a score of 550 or above on Level I, IC, II or IIC (C=Calculator) of either the College Board Mathematics Achievement Test or SAT II: Mathematics Test taken before March 2005
- a score of 23 or above on the ACT Mathematics Test taken October 1989 or later
- a score of 3 or above on the College Board Advanced Placement Calculus AB or Calculus BC examination
- a score of 3 or above on the College Board Advanced Placement Statistics examination
- completion and transfer to the CSU of a college course that satisfies the requirement in Quantitative Reasoning, provided such a course was completed with a grade of C or better.

\*NOTE: The College Board SAT I and SAT II were renamed SAT Reasoning and SAT Subject Tests, respectively, beginning March 2005.

**PENALTIES:** Unless you are exempt, you **must** take the EPT and the ELM prior to enrollment in the CSU. According to CSU Executive Order 665, if you do not take these tests prior to the time of enrollment, you will not be allowed to enroll.

**PLEASE NOTE:** If you do not demonstrate college-level skills on the EPT and/or ELM, any remedial courses you take in order to attain such skills will not be counted toward completion of a bachelor's degree.

## WHERE THE TESTS WILL BE GIVEN

The EPT and ELM will be given at CSU campuses on the dates published on the inside back cover and back cover of this Bulletin. You may register to take the tests at whichever campus you choose. You need not take the tests at the campus you plan to attend. If you complete EPT and ELM requirements, you do not have to fulfill these requirements again if you transfer to another CSU campus.

If you live outside the state of California and have been admitted to a CSU campus and need to take the EPT and/or the ELM before arriving in California, please call (925) 808-2142 or e-mail <csuout-of-state@ets.org>. Out of state testing is arranged for the 2<sup>nd</sup> week of each month except May when it is scheduled for the first week. There is a \$50 fee for testing outside of California.

## INQUIRIES ABOUT THE TESTS

Students register for EPT and/or ELM at their local campuses. (Do not send your registration form to ETS.) Most questions concerning whether or not you need to take the EPT/ELM or other questions regarding EPT/ELM status can be answered by your campus Admissions and Records Office. You should address questions about test dates and registration materials to your campus Test Office. Your campus English and mathematics departments can answer questions about placement and remedial courses. Campus Admissions and Records and English/mathematics department numbers are in the campus directory. Test Office addresses and telephone numbers are listed on page 22 of this Bulletin.

Test scores are maintained permanently by ETS. Duplicate score reports can be ordered by sending a check in the amount of \$10 times the number of duplicate score reports you desire, payable to Educational Testing Service, accompanied by a letter indicating your name, social security number, the date on which you took the test, and the address to which you want the duplicate score report sent. Sign the check and send it and the letter to:

Educational Testing Service  
EPT/ELM Program  
2731 Systron Drive  
Concord, CA 94518

Anyone who takes the EPT and/or the ELM has the right to ask questions and air concerns about the tests themselves and about how they are scored and to have such questions or concerns answered in a timely fashion. If you have questions and concerns, please write them down and send them to the address given above. However, please read page 6 below, "Scores on the EPT and ELM," before sending in questions about scores and what they mean.

Test answer sheets and booklets are retained by ETS for 18 months. Essays are retained for 6 months. Although test security reasons make it impossible for ETS to provide you with copies of test materials (such as test books), you have the right to inspect a copy of your answer sheet and/or your EPT essay at the ETS branch office located at 2731 Systron Drive, Concord, California. Requests for inspection may be made to **(925) 808-2142** or, by e-mail, to <cgrueter@ets.org>.

Questions about EPT/ELM policies and procedures that cannot be handled at the campus can be referred to ETS at **(925) 808-2142** or to:

CSU Systemwide Testing Coordinator  
Office of the Chancellor  
401 Golden Shore, 6th Floor  
Long Beach, CA 90802-4210  
**(562) 951-4731 or (562) 951-4726.**

## EPT AND ELM REGISTRATION

CSU campuses provide registration materials for EPT and/or ELM. Directions for completing and mailing registration forms are included on the back of the form itself. If you are required to take the test(s) but do not receive a registration form, you may pick up a copy at any CSU Admissions Office or Test Office. (See "[Who Must Take the EPT/ELM](#)" on page 3.) Every student should have a social security number. CSU campuses use the social security number to identify your student records maintained during your association with the campus. If you do not have a social security number at this time, you must register for the EPT or ELM by using the temporary number that was assigned by the Admissions Office at the campus you plan to attend. You should obtain a social security number and submit it to the University by the time you enroll. International students who do not have a social security number should use a taxpayer identification number.

Registration is required for the test. Many campuses have on-line registration available. Other campuses require you to complete the registration form and mail it to the Test Office of the campus where you plan to take the test. Pages ?? and ??, the Test Dates, will indicate if a campus offers on-line registration. You can also go to the campus website. Web addresses along with address and telephone numbers of the Test Office at each campus are listed on the last page of this Bulletin. *Call the Test Office on the campus where you plan to take the test(s) if you have questions about how to fill out the registration form.*

The registration form permits you to register for both the EPT and ELM at one administration, for the EPT only, or for the ELM only. If you meet all of the qualifications for exemption from both the EPT and the ELM, no registration form need be submitted. (See page 3 for exemptions.) Please call the Admissions and Records Office or the Test Office at the CSU campus you plan to attend if you need further information.

## Fees

ELM fee is \$18;

EPT fee is \$18.

Out of State Testing fee is \$50.

Duplicate Score Report is \$10.

Fees are non-refundable.

Note: By paying with a check, be aware that you are authorizing ETS at its discretion to use the information on your check to make a one-time electronic debit from your account for the amount of your check; no additional amount will be added. If you do not have sufficient funds in your account, an additional service fee of \$20.00 will be debited electronically from your account.

## Incomplete or Late Registrations

An incomplete or late registration form may be returned to you. Early registration is recommended. CSU test centers fill up on a first-come, first-serve basis, and students requesting a center after it is full may not be able to take the EPT and/or ELM at that center until the next scheduled administration.

## Walk-in Registration

If some situation prevents you from meeting the registration deadline, walk-in registration may be available on a first-come, first-serve basis. You should check with the Test Office on the campus at which you wish to test to see whether walk-

in registration is available. Remember that because you are not already registered for the test, you will be admitted only if ample room and test materials are available. See “What to Bring to the Test Center” on page 5.

### Test Center Changes

To change a test center prior to the registration deadline date, submit a new registration form to the Test Office at the campus where you wish to take the test(s). If the registration deadline has passed, you can proceed as a walk-in candidate, but be sure to check with the campus regarding walk-in availability before taking this step.

### Special Arrangements

If special circumstances make it impossible for you to take the test(s) at the first available administration, you **must** plan to meet the requirement at the next scheduled opportunity. Each test administration requires a separate registration form. If your religious convictions prevent you from taking the EPT and/or ELM on the scheduled test dates, you must request special arrangements by including a letter from an appropriate religious authority with your registration form. If you have a disability and require special arrangements for taking the examination(s), you should contact the campus Test Officer or Disabled Student Services Coordinator by the published registration deadline (see inside back cover and back cover). The EPT and ELM are available in Braille, large-print, and cassette editions.

### Admission Tickets

Campuses will send you validated admission tickets one or two weeks before the test(s). Your ticket will show the test(s) you are registered to take, the address of the test center, and the time to report. Since there may be more than one test administration on a campus, reporting times and addresses may not be the same for all students taking the test(s) at that campus.

If you mail your registration form before the registration deadline but do not receive an admission ticket within three days of the test date, you should contact the campus Test Office.

## TESTING SCHEDULE

The amount of time required for the combined EPT and ELM is as follows:

#### I. ENGLISH PLACEMENT TEST

Essay	—	45 minutes
<u>Multiple-Choice</u>		
Section 1	—	30 minutes
Section 2	—	30 minutes

#### II. ENTRY LEVEL MATHEMATICS TEST 90 minutes

Please note that the above schedule includes only actual testing time. In reality, you should plan on a minimum of 2 ½ hours for the English Placement Test and a minimum of 2 hours for the Entry Level Mathematics Test. The additional time is required in order to check you and your fellow students in at the testing site, distribute testing materials, give the necessary instructions for taking the test, and then collect the testing materials at the end of the test. **You cannot be dismissed prior to the end of an EPT-only administration. Students may be dismissed, one at a time, before the end of an ELM administration. However, in order to avoid disturbing fellow students, you may**

**not be dismissed during the final 10 minutes of an ELM administration.**

If you have any questions about the testing schedule, contact the CSU Test Office where you plan to take the test. The addresses and phone numbers for the Test Offices are on page 22 of this *Bulletin*.

## WHAT TO BRING TO THE TEST CENTER

You **must** bring to the test center:

- your social security number.
- acceptable identification. “**Acceptable**” means that the ID includes a photograph or physical description written in English, your name, and your signature. Examples are: (1) driver’s license with photo; (2) school ID card with recognizable photo; (3) valid passport with your signature and current, recognizable photo; (4) a document on your high school’s stationary bearing your name and a brief physical description in English (height, weight, age, sex, eye color, and hair color). You must sign this document in the presence of your principal or school counselor, who must also sign it. You may be asked to sign this ID form again at the test center. **Unacceptable** ID includes (1) social security card; (2) credit card (including one with a photo); (3) parent’s driver’s license; (4) birth certificate (including wallet-size birth certificates). **You will not be admitted to the test without an acceptable ID.** The Supervisor **cannot** make exceptions to this rule.
- your validated admission ticket.
- check or money order, payable to ETS for test fees. Your name must appear on the face of the check. You will **not** be admitted to the EPT and/or ELM examinations without the appropriate test fee.
- ELM fee is \$18; EPT fee is \$18.
- several No. 2 lead pencils with erasers. When you take the test(s), you will be required to record your answers on a machine-processable answer sheet and to use only a No. 2 pencil. Specific directions for completing your answer sheet will be given to you at the test center. It is your responsibility to bring No. 2 pencils to the test center and to make certain you understand and follow the directions for completing your answer sheet. Responsibility for accurately scoring your test(s) can be accepted only if your answer sheet is completed according to directions.
- two ballpoint pens for writing the EPT essay.

You **may** bring to the test center:

- a watch (without audible alarm)
- a bag or backpack (must be kept on the floor under your chair).

## TEST ROOM REGULATIONS

Books, rulers, papers of any kind, and recording or photographic devices are not allowed into the testing room. **You may not bring a calculator, personal digital assistant (PDA), cellular telephone or pager.** Eating, drinking, and smoking are **not** permitted in the buildings.

You may be dismissed from the test if you use notes or any of the prohibited aids; give or receive help during the test; attempt to take the test for someone else; fail, after being warned, to follow the test supervisor’s instructions; work on one section of the test during the time allotted for another section; cause undue disturbance; attempt to copy test materials; or remove test materials from the room.

**CSU reserves the right to cancel any test score if the test taker engages in misconduct or if there is a testing irregularity.** Because there is an obligation to report scores

that accurately reflect the performance of each test taker, test administration and test security standards have been designed to assure that all test takers are given the same opportunity to demonstrate their abilities and to prevent some test takers from gaining an unfair advantage over others because of testing misconduct.

All testing irregularities as well as test scores believed to be earned under unusual or nonstandard circumstances are routinely reviewed.

When you are taking the test, be sure to mark your answers on the answer sheet and not in the test book. You may use the test book for scratchwork, but you will not receive credit for any responses written in it. Both the EPT and ELM are scored according to right answers only, so there is no penalty for guessing.

If you wish to leave the room briefly during the test to use the rest room, you must have the supervisor's permission. Only one person at a time is permitted to leave the test in order to use the rest room. You will not be permitted to make up the time you lose.

If you wish to register a comment or complaint about either test conditions or a test question, you may do so with the test supervisor after the test. The supervisor will report your comment on an irregularity form, and it will be reviewed.

If, upon completing the test, you decide that you do not want to have your score reported, you may cancel it by informing the test supervisor (after the test session is finished) that you would like to have your score canceled.

## CONFIDENTIALITY OF SCORES

ETS releases EPT and ELM scores only to the California State University Chancellor's Office and Systemwide Testing Coordinator, the campus Admissions and Records Office, the English and mathematics departments, the Testing Office on each CSU campus, and the individual EPT and/or ELM test takers. Once a year, summaries of EPT/ELM passing rates are provided on the world wide web (<http://www.asd.calstate.edu/performance/>), for those students who took the tests and enrolled in the CSU for the fall term. In order to preserve the anonymity of the test candidates and to ensure the confidentiality of their scores, no individual names or scores are given. The California State University abides by all federal and state laws protecting the confidentiality of student data.

## SCORES ON THE EPT AND ELM

Because the EPT and the ELM are placement tests, they use "cut scores." If you score at or above these cut scores, you will be placed in regular, college-level English or mathematics courses. If you score below the cut scores, you will need some remedial instruction in these fundamental disciplines. The cut score for each test was set by CSU faculty members.

The cut score for the EPT is 151 on a scale that goes from a lowest possible score of 120 to a highest possible score of 180. If your total score for the EPT is 151 or above, you are ready for college-level English. If you score below 151, you will have to do some remedial work. If you score below 142, you will require fairly intensive remedial instruction to help you attain the skills you need to succeed in regular college English courses.

In addition to your total EPT score — the score on which placement decisions are based — you will receive separate scores on the component parts of the EPT, Reading Skills, Composing Skills, and the Essay. The Reading Skills and Composing Skills scores are reported on the same 120 to 180 point scale on which the total score is reported. The Essay score is different. Your essay will be read by two

members of the CSU English faculty, neither one of whom will know what score was given to it by the other. The scores range from 6 — the highest — to 1 — the lowest. Your score is determined by adding the scores assigned by the two readers. For example, if one reader awards your essay a 5 and the other awards it a 4, your Essay score will be a 9. If the two readers differ in their judgment by more than one point, then a third reader is brought in as an adjudicator.

Scores on the ELM are reported on a scale running from 0 to 80. It is essential to note that scaled scores earned on the ELM before the March 23, 2002 administration were reported on a different scale (a scale running from 100 to 700). You cannot compare ELM scores earned before March 23, 2002 to those earned on ELM tests administered on or after this date. The cut score for the ELM is 50 on the 0 to 80 ELM scale.

If you receive a total ELM scaled score of 50 or above, you are ready to enroll directly in a baccalaureate quantitative reasoning course. If you receive a total scaled score below 50, you will have to take developmental coursework in math.

If you tested between March 23, 2002 and March 17, 2006 you will have received three scaled subscores— one for each of the three content area covered by the ELM (Numbers and Data, Algebra, and Geometry)— as well as your total scaled score. The subscores will be represented graphically as score ranges on the 0-80 scale. The score of 50, which demonstrates proficiency, will be indicated by a vertical line on this scale.

If your total score is well below the cut score, you probably stand to benefit from more intensive help in all the content areas.

An individual student score report will be mailed to you after your test administration. This score report will show your EPT and/or ELM scores as described above.

## RELIABILITY

The particular editions of the EPT and the ELM that you will take are similar, but not identical, to the editions that other students will take on other testing dates. The format and the kinds of questions asked are identical from edition to edition, but the exact questions themselves are not all the same. Testing experts say that a test such as the EPT or the ELM is "reliable" if you would earn pretty much the same score no matter which edition of the test you happen to take — even though the exact questions on one edition differ from those on another. A test that is perfectly reliable (that is, any student would earn exactly the same score no matter which edition he or she happened to take) is said to have a reliability of 1. In real life, of course, no test is perfectly reliable. That is, reliability is always less than 1. The closer it is to 1, of course, the better. The reliability of the EPT ranges between .89-.93; the reliability of the ELM ranges between .81 and .83. Reliability values such as .89-.93 and .81-.83 suggest that both EPT and ELM are reliable enough so that the "luck of the draw" — that is, which editions you happen to end up with on the day you take the EPT and the ELM — does not matter very much. Both tests are reliable enough to ensure that the EPT and the ELM will yield consistent placement decisions across different editions of either test.

## STANDARD ERROR OF MEASUREMENT

When you take a test such as the EPT or the ELM, your performance is influenced by many little factors in the test aside from the major factor — your proficiency in English and mathematics skills. Different EPT test forms are parallel to

each other in format, content, and number of questions even though the exact questions are different on each form. The same is true of different ELM test forms. It is highly unlikely that you would get exactly the same score on two different parallel forms of the test. As you confront each test question, your level of concentration may vary; you may inadvertently mark your answer sheet in the wrong place even if you know the answer to a question, and so on. On the other hand, you may guess the answer correctly for a number of questions that are difficult for you. If you were to take several different forms of the same test, the pattern of all these little changes in level of concentration, minor mishaps, or strokes of good luck is going to be different each time. As a result, your score would be a little different each time. Sometimes your score would be a little lower than what testing experts call your “true score” — that is, the score that represents the perfect measure of your proficiency in English or mathematics skills. Sometimes your score would be a little higher than your true score. Mathematically speaking, your true score is the average score you would receive if you completed a very large number of parallel forms of the same exam. Any score you earn in real life is, in fact, an approximation of your true score. Testing experts have a way of calculating how far (higher or lower) peoples’ actual scores are likely to be from their true scores. This calculation is called the “standard error of measurement,” or SEM. The SEM for the EPT is between 2 and 3 points on the score reporting scale of 120 to 180. That is, anyone’s actual score will typically fall between 2 and 3 points on either side of his or her “true score.” The SEM for the ELM is 5 on the score reporting scale of 0 to 80.

## QUESTIONS AND ANSWERS ABOUT THE EPT

- Q** Is this an admission test?
- A** No. The results of the test will not affect your admission to any CSU campus.
- Q** I have not yet been admitted. Can I still take the test?
- A** You should wait for the first scheduled test administration after you have been admitted unless the campus asks you to take the test earlier. However, you should take the test at your earliest opportunity after admission. You **must** take the test before you can enroll in CSU General Education courses.
- Q** I have completed freshman English at another university. Do I need to take the EPT?
- A** Maybe. The EPT is not required if you have completed and transferred a campus-acceptable four-quarter or three-semester unit college English composition course with a grade of C or better.
- Q** Do I need to take the EPT if I did well on admission tests such as the SAT?
- A** No. A score of 550 on the verbal section of SAT I exempts you, while a 3, 4, or 5 on either the Language and Composition or the Literature and Composition examination of the College Board Advanced Placement Program gives you six units of credit and exempts you from the EPT. See page 3 for other grounds for exemption.
- Q** I have a high GPA in my high school English classes. Do I still have to take the EPT?
- A** Yes. GPA is not a consideration in determining whether or not you have to take the EPT. The only grounds for exemption are those listed on page 3 of this Bulletin.
- Q** I am still unsure whether I am required to take the EPT. What should I do?
- A** The staff of the Admissions Office or the Test Office of the CSU campus that you plan to attend will be able to answer your questions.
- Q** Why are you testing English?
- A** Unless you read well enough to understand your textbooks and write well enough to complete essay tests and term papers, you will have difficulty in your other subjects. Reading and writing skills are basic.
- Q** What is the relationship of this test to the graduation requirements of my college?
- A** The CSU Board of Trustees has called for a graduation requirement in student writing proficiency for all degree candidates. The EPT will help you prepare to meet that requirement at your campus by giving you descriptive information about your reading and writing skills.
- Q** How do I prepare for the test?
- A** The test does not ask for information but examines reading and writing skills. You develop these skills with steady practice over a period of years.
- Q** I have had English in high school. Shouldn't I be ready for college-level reading and writing?
- A** Probably. But if you have not had very much practice in writing essays or in careful reading, you still might benefit from special instruction.
- Q** Suppose I don't do well on the test?
- A** CSU requires that all students who do not do well on the EPT be placed in a remediation course or activity during the first term of enrollment. The test is designed to help your college give you help if you need it. A low score means that you probably need extra help in order to do well in college. It is better to identify any reading or writing problems before they contribute to lowering your course grades; however, a low score on the EPT will not directly affect your grade point average. You should consider the score useful information, not "failure." Of course, no test is perfect. Teachers in basic skills courses are trained to identify students who are ready to advance rapidly despite low test scores.
- Q** Will I have to pay for extra help if I receive a low score?
- A** Probably not. Each CSU campus receives funds from the state of California to operate its educational programs. Each campus develops its own basic skills program within the limits imposed by available funds.
- Q** I will be out of the country on the first test date available. What do I do?
- A** You must take the test at the next opportunity. It is to your advantage to take the test as soon as possible, and you **must** take it before you can enroll in CSU General Education courses.
- Q** Do I have to take the test at the campus I will be attending?
- A** No. Plan to take the test at whichever campus is most convenient for you. Your score will be sent to the campus that has admitted you.
- Q** How much time do I have to complete the test?
- A** You have 45 minutes to complete the essay portion and 60 minutes to complete the combined multiple-choice portion (30 minutes for each of the two sections). If you are taking the ELM test at the same sitting, be prepared to test an additional 90 minutes for the ELM.
- Q** How do I receive my test scores?
- A** Your test scores will be mailed to you at an address you will provide on the day of the test.
- Q** How long are my EPT testing materials and scores retained by ETS?
- A** ETS retains essays for 6 months and answer sheets and test books for 18 months. Although essays and answer sheets (not test books) are available for review at the ETS office in Concord, they may not be returned to students. EPT scores are available from 1977 to the present.

## EPT TEST DESCRIPTION

The purpose of the English Placement Test is to determine whether you are prepared to undertake college-level work in reading and writing. The results of the test will be used to place you in an appropriate course.

The English Placement Test requires one hour and 45 minutes to administer and contains the following three sections:

Essay	45 minutes – one assigned topic
Reading Skills	30 minutes – 45 multiple-choice questions
Composing Skills	30 minutes – 45 multiple-choice questions

This test is divided into three sections. The first section asks you to write an essay. The next two sections, made up of multiple-choice questions, assess your ability to comprehend and interpret reading material and your understanding of sentence construction and paragraph development.

### What scores will you receive?

- **Total Test Score** — Your Total score is the combined scores of all three sections. It will indicate whether you have the skills in English that will permit you to perform according to the standards expected of you in regular college English courses. A low Total score indicates that you should enroll in a class or laboratory designed to improve your English skills.
- **Reading Skills Score** — Your score on the Reading Skills section of the test will indicate whether you are reading on a college-entry level or whether you should receive special instruction in reading.
- **Composing Skills Score** — Your score on the Composing Skills section of the test will indicate your ability to select sentences that establish clear meaning, your knowledge of sentence structure according to the conventions of standard written English at the college-entry level, and your ability to recognize statements that support or help develop a given idea.
- **Essay Score** — Your score on the essay will indicate whether you have the skills necessary to write in-class papers or examinations in college.

The following sections describe the EPT and provide sample test questions similar to those found on the actual test. More detailed information about EPT test specifications can be found in the CSU publication *Focus on English*, available in your guidance counselor's office and in the Test Offices and English departments located on all CSU campuses. *Focus* is also available on the Web at <http://www.calstate.edu/AR/EPT.PDF>.

### The Essay — 45 minutes

The English Placement Test begins with the essay assignment. You will have 45 minutes to plan and write an essay on the topic specified in the essay booklet. Do not write on a topic other than the one specified; an essay on a topic of your own choice is not acceptable.

The EPT essay topic presents a paragraph-length passage in the form of an argument: in other words, the author of the passage makes a claim that he or she supports with reasons and evidence. You will be asked to analyze and explain the ideas presented in the passage and then evaluate those ideas in light of your own experience,

observations, and reading. Because the writing assignment requires you to analyze the author's ideas in developing your own position on the subject, it integrates the critical reading and expository writing skills that are both essential to college-level work.

Below is a sample EPT essay topic— the topic that asks you to take and defend a position and the text-based topic about to be introduced. Both samples include directions.

**Directions:** You will have 45 minutes to plan and write an essay on the topic assigned below. Before you begin writing, read the passage carefully and plan what you will say. Your essay should be as well organized and as carefully written as you can make it.

“For many Americans, the concept of success is a source of confusion. As a people, we Americans greatly prize success. We are taught to celebrate and admire the one who gets the highest grades, the one voted most attractive or most likely to succeed. But while we often rejoice in the success of people far removed from ourselves —people who work in another profession, live in another community, or are endowed with a talent that we do not especially want for ourselves—we tend to regard the success of people close at hand, within our own small group, as a threat.”  
— Adapted from Margaret Mead,  
The Egalitarian Error

Explain Mead's argument and discuss the extent to which you agree or disagree with her analysis. Support your position by referring to the passage and providing reasons and examples from your own experience, observations, or reading.

**Scoring your essay:** The CSU faculty members who rate your essay will expect you to write a well-organized essay, one in which you develop your ideas clearly and logically. Sentence and paragraph structure, usage, and grammar also contribute to your final essay score. Each essay is read and scored holistically by two different faculty members using a scoring guide that helps to define degrees of writing proficiency. The two readers' scores are totaled to give your reported essay score, which will fall between 2 (low) and 12 (high). A score of 0 is given to essays not written on the assigned topic. For more information about the scoring process, including a copy of the EPT scoring guide, please see the CSU publication *Focus on English* at <http://www.calstate.edu/AR/EPT.PDF>.

### Reading Skills — 30 minutes

The Reading Skills section consists of 45 multiple-choice questions. Some questions, based on short passages, ask you to identify or interpret ideas stated directly or indirectly in the text. Other questions assess your ability to determine the word that best fits the meaning of a sentence. Still other questions ask you to identify the logical relationship between sentences.

The directions for each type of question and a few sample questions follow. Remember that the actual test will present a total of 45 questions covering these three types of questions. Five questions, usually one or two of each type, are being given for field-testing purposes and will not count toward your score.

**Directions:** Each passage below is followed by questions based on its content. Answer all questions following a passage on the basis of what is stated or implied in that passage.

### Questions 1-3

The search for a workable panacea is not new. Spanish explorers sought the Fountain of Youth. Millions of Americans used to seek health and contentment in a patent medicine called Hadacol. During the past two decades, however, more and more people have been turning to various branches of psychology for magic solutions, hoping that psychology can take care of any hang-up, cure the common cold, or solve the riddle of existence.

- From the whole passage one can learn that the word "panacea" means  
 (A) paradise (B) religion  
 (C) cure-all (D) life style
- What do the Fountain of Youth and Hadacol have in common?  
 (A) Neither really existed.  
 (B) Both brought their discoverers great fortunes.  
 (C) Both helped to end the search for magic solutions.  
 (D) Both were thought to have great power.
- What does the passage call into question?  
 (A) People's expectations for psychology  
 (B) The legitimacy of the field of psychology  
 (C) The relationship between psychology and medicine  
 (D) People's uses of the lessons of history

### Questions 4-5

Americans have given a new meaning to the term "spectator sports" by sometimes "attending" a game without making it into the stadium. Starting with the plans for the pregame tailgate parties in the parking lot, fans orchestrate every facet of the outing. When a cheer from the stands signals the beginning of the game, these fans rush to the car radio or peer intently into a portable television. Despite dedicated thermos emptying, dial twisting, and extensive planning for the next outing, they sometimes even manage to learn who won.

- The passage implies that the spectators mentioned are most interested in  
 (A) getting publicity for themselves  
 (B) turning the sports event into a social occasion  
 (C) analyzing the important plays of the game  
 (D) using all means possible to be informed
- The author uses the phrases "dedicated thermos emptying" and "dial twisting" to suggest that these spectators  
 (A) are usually intense and enthusiastic  
 (B) tend to take technology for granted  
 (C) spend much time on activities other than watching the game  
 (D) probably enjoy the game more than do those inside the stadium

**Directions:** For each of the following questions, choose the best word or phrase to substitute for the underlined portion containing gliff, a nonsense word.

#### Example:

Though Mr. Rivera is a gliff man and could live anywhere he chooses, he still lives in the small house in which he was born.

- (A) a careful  
 (B) a wealthy  
 (C) an ambitious  
 (D) a strong

A B C D

- The water looked fine for swimming, but in fact the currents in the river were gliff.  
 (A) emphatic (B) soothing  
 (C) treacherous (D) unnoticeable
- Many of the problems we have with our natural resources could be gliffed if all of us did what we could to conserve those resources.  
 (A) avoided (B) defined  
 (C) accentuated (D) understated

**Directions:** In each of the following questions, the two underlined sentences have an implied logical relationship. Read each pair of sentences and the question that follows, and then choose the answer that identifies the relationship.

**Example:**

Donna is six feet tall.

Her cousin is two inches shorter than she is.

In relation to the first sentence, what does the second sentence do?

- (A) It provides an example.  
 (B) It makes a comparison  
 (C) It makes an exception.      A   B   C   D  
 (D) It provides emphasis.

8. Last year the goal of the Red Cross was to provide area hospitals with 80 million pints of blood.

This year the goal is to provide 100 million pints.

In relation to the first sentence, what does the second sentence do?

- (A) It gives a reason.  
 (B) It draws a conclusion.  
 (C) It states a consequence.  
 (D) It makes a comparison.

9. The gigantic waves and high tides combined to destroy life and property.

Two people drowned and ten homes were washed into the sea.

In relation to the first sentence, what does the second sentence do?

- (A) It introduces a new subject.  
 (B) It gives supporting evidence.  
 (C) It provides contrasting information.  
 (D) It suggests a cause.

**Answers to Sample Questions in the Reading Skills Section**

- |      |      |      |
|------|------|------|
| 1. C | 4. B | 7. A |
| 2. D | 5. C | 8. D |
| 3. A | 6. C | 9. B |

**Composing Skills — 30 minutes**

The Composing Skills section consists of 45 multiple-choice questions. In this section, your composing skills are assessed in several different ways. One kind of question asks you to read a statement and restructure it. Another asks you to select which version of a sentence is worded clearly, logically, and correctly. A third type presents a paragraph with a missing sentence; you must choose a sentence that logically begins, develops, or concludes the ideas in the paragraph. Finally, a fourth type of question presents a topic and asks you to select the information that most clearly supports the topic.

Below are the directions for the various types of questions and examples of each. Remember that in the actual test, this section will have 45 questions. Five of these questions, usually one or two of each type, are being given for field-testing purposes and will not count toward your score.

**Directions:** The following questions require you to rewrite sentences in your head. Each question tells you exactly how to begin your new sentence. Your new sentence should have the same meaning and contain the same information as the original sentence.

**Example:**

The student senate debated for two hours and finally voted down the resolution.

Rewrite, beginning with

Having debated the issue for two hours, ...

The next word or words will be

- (A) the issue  
 (B) it  
 (C) the student senate      A   B   C   D  
 (D) a vote

1. Photographers, hoping to get good shots of the colorful birds, accidentally damaged the birds' nesting grounds.

Rewrite, beginning with

The birds' nesting grounds were accidentally damaged ...

The next words will be

- (A) in the hopes of photographers who  
 (B) and photographers hoped  
 (C) by photographers who  
 (D) by hoping that photographers

2. A panel of distinguished judges was selected by the trustees of the Smithsonian Institution to decide which inventions had been most beneficial to our society.

Rewrite, beginning with

The trustees of the Smithsonian Institution . . .

The next word or words will be

- (A) with their selection of  
 (B) in deciding  
 (C) selected  
 (D) had been the

**Directions:** In each of the following questions, select the best version of the underlined part of the sentence. Choice (A) is the same as the underlined portion of the original sentence. If you think the original sentence is best, choose answer (A).

**Example:**

Ancient Greeks ate with their fingers, wiped them on pieces of bread, and tossed them to the dogs lying under the table.

- (A) tossed them  
 (B) tossing them  
 (C) tossed the bread  
 (D) they tossed

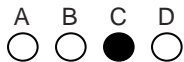

3. After the enormous mud slide of May 1983, about 3 million cubic yards of rock and soil were removed from the Pacific Coast Highway, and they required a fleet of 30 bulldozers and 7,700 pounds of explosives.
- (A) and they required  
 (B) and it required  
 (C) a job requiring  
 (D) a job where it required
4. On his second voyage, Captain Cook found that Tahitian breadfruit, which becomes rich in vitamin C after long storage, and this helped his crew members resist scurvy.
- (A) storage, and this helped  
 (B) storage, helped  
 (C) storage and helped  
 (D) storage, helping

**Directions:** Each of the following questions presents a passage with a missing sentence indicated by a series of dashes. Read each passage and the four sentences that follow it. Then choose the sentence that can best be inserted in place of the dashes.

5. ----- . Being elected to the House of Representatives brought her national prominence in 1972, but she had a noteworthy record before that. In 1966 she became the first Black woman to serve in the Texas Senate, where she was named outstanding first-term Senator and was later elected Senate President pro tem.
- (A) Barbara Jordan spoke with a style that was at once matter-of-fact and eloquent.  
 (B) A believer in effecting change through the political system, Barbara Jordan supported certain pieces of key legislation.  
 (C) Barbara Jordan was only one of many outstanding women elected to national office.  
 (D) For many years, Barbara Jordan was a leading political figure.

6. Although the high school that I attended was wonderful, it had one big drawback. It had — and enforced — a strict dress code for students. ----- . Our daily apparel consisted of a gray sweater (imagine damp putty), Peter Pan collared white blouse, plaid skirt, and clumpy brown Oxford-style shoes.
- (A) Without fail, day in and day out, we donned a dreary combination of clothes.  
 (B) Nevertheless, having to dress alike was the least of our worries.  
 (C) I tended to resist anything that would keep me from expressing my individuality.  
 (D) Teenagers like to follow fashion trends without being restricted by old-fashioned ideas — or old fashions, for that matter.
7. As school populations decline, more and more schools will have to be closed. Then the empty buildings will pose a problem to their immediate neighborhoods. ----- .
- (A) Perhaps the school population is declining because the size of the average family is declining.  
 (B) We should all realize that nothing is so important as the education of our children.  
 (C) It would therefore be wise to begin planning as soon as possible for the best future use of these buildings.  
 (D) Therefore, no single neighborhood should be held responsible for what it cannot avoid.

**Directions:** Each of the following questions presents a topic and four sentences. Select the sentence that provides the best support for the topic presented.

8. Many people who have extensive collections become extremely knowledgeable about what is in them.
- (A) Collecting sculptures and paintings can be an expensive hobby, even for very wealthy people.  
 (B) Chester Nakamura became an expert on Samurai swords by researching his own collection.  
 (C) Sara Johnson's private collection of rare books is so extensive that she had to add a large library to her home.  
 (D) Doing something and knowing about it are two different things.
9. Louise is older than most other applicants to medical school, but no one can doubt her desire to attend.
- (A) Some schools have witnessed a rapid increase in the number of female applicants.  
 (B) Over 42,000 people applied to medical schools last year.  
 (C) She has read several newspaper articles having to do with headaches.  
 (D) She worked as a hospital orderly for several years to earn the money for tuition.

**Answers to Sample Questions in the Composing Skills Section**

- |      |      |      |
|------|------|------|
| 1. C | 4. B | 7. C |
| 2. C | 5. D | 8. B |
| 3. C | 6. A | 9. D |

## QUESTIONS AND ANSWERS ABOUT THE ELM

- Q** Is this an admission test?
- A** No. The results of the test will not affect your admission to any CSU campus.
- Q** I have not yet been admitted. Can I still take the test?
- A** You should wait for the first scheduled test administration after you have been admitted unless the campus asks you to take the test earlier. However, you should take the test at your earliest opportunity after admission. You **must** take the test before you can enroll in CSU General Education mathematics courses.
- Q** I took the SAT examination and I scored 610 on the math part. Do I need to take the ELM examination?
- A** No. If you scored 550 or above on the SAT I – Math, 23 or above on the ACT math test (given October 1989 or later), 3 or above on the AP mathematics test (Calculus AB, Calculus BC, or Statistics), or 550 or above on the College Board SAT II Mathematics test, level IC or IIC, you are exempt from the ELM examination. Transfer students may be exempt through transferred coursework. See page 3 of this Bulletin for more details.
- Q** What about the UC/CSU Mathematics Diagnostic Testing Program (MDTP) tests? I took one of those and did well. Do I have to take the ELM test?
- A** Yes, you do. However, those are rigorous tests and are excellent indications of mathematics skills. If you scored well on the MDTP intermediate algebra examination, you should do well on the ELM examination.
- Q** I have a high GPA in my high school math classes. Do I still have to take the ELM?
- A** Yes. GPA is not a consideration in determining whether or not you have to take the ELM. The only grounds for exemption are those listed on page 3 of this Bulletin.
- Q** I am still unsure whether I am required to take the ELM test. What should I do?
- A** The staff of the Admissions Office or the Test Office of the CSU campus that you plan to attend will be able to answer your questions.
- Q** May I use a calculator during the ELM exam?
- A** No. The questions on the ELM do not require involved computation. Rather, the test includes problems that emphasize quantitative reasoning and problem solving.
- Q** Why are you testing math?
- A** With science and technology playing an increasingly important role in our society, all college-bound students — not just those who show special aptitude or interest — must have an adequate grasp of mathematics. More and more undergraduate majors require some proficiency in math, and many require either calculus or statistics or both.
- Q** What is the relationship of this test to the graduation requirements of my campus?
- A** Basic mathematics provides the necessary background for the CSU general education quantitative reasoning requirement, which consists of a course at the level of College Algebra or higher. Such a course is required for graduation. Completion of the ELM requirement is prerequisite to that course.
- Q** How do I prepare for the test?
- A** Studies have shown that if you do not continue to use the math you have learned, you may have trouble recalling simple principles. If you have taken less than three years of college preparatory mathematics or have not used your math knowledge in some time, additional work and review may be necessary. An algebra review text, learning assistance center, or a copy of the ELM Problem Book (available on-line at [www.calstate.edu/AR/ELMProblemBook01\\_02.pdf](http://www.calstate.edu/AR/ELMProblemBook01_02.pdf)) may be of use in helping you prepare. Additional information is available at [www.csumathsuccess.org](http://www.csumathsuccess.org).
- Q** I had plenty of math in high school. Shouldn't I be ready for college-level math?
- A** Probably. But if you have not had very much practice in using your math recently, you will still benefit from a review.
- Q** Suppose I don't do well on the test?
- A** CSU requires that all students who don't do well on the ELM be placed in a developmental course or activity during the first term of enrollment. The test is designed to help your college give you help if you need it. A low score means that you probably need extra help in order to do well in general education courses that require skills in algebra, geometry, data interpretation, and statistics.
- Q** Will I have to pay for extra help if I receive a low score?
- A** Probably not. Each campus offers different services for students who need help in basic mathematics. For example, some campuses offer prebaccalaureate courses in the mathematics department, others have established remedial courses in the continuing education program, and still others have instituted tutorial programs using graduate students and peer tutors. Some campuses are developing modularized programs, structured so as to parallel cluster topics in the ELM specifications; others are exploring programmed instruction, especially using interactive computer software.
- Q** I will be out of the country on the first date available. What do I do?
- A** You must take the test at the next opportunity. It is to your advantage to take the test as soon as possible, and you **must** take it before you can enroll in a CSU General Education mathematics courses.
- Q** Must I take the test at the campus I will be attending?
- A** No. Plan to take the test at whichever campus is most convenient for you. Your score will be sent to the campus that has admitted you.
- Q** How do I receive my test scores?
- A** Your test scores will be mailed to you at an address you will provide on the day of the test.
- Q** How long are my ELM testing materials and scores retained by ETS?
- A** ETS retains answer sheets and test books for 18 months. Although answer sheets (not test books) are available for review at the ETS office in Concord, they may not be returned to students. ELM scores are retained for the life of the program and are available from 1983 to the present.

## ENTRY LEVEL MATHEMATICS EXAMINATION

### ELM TEST DESCRIPTION

This test is designed to measure your mathematical preparedness for college level courses. It consists of 50 questions. Only 45 of these questions contribute toward your score. The remaining 5 questions, scattered throughout the test, are included for field testing for possible use on future versions of the test.

The ELM placement test described in this Bulletin made its debut at the March 23, 2002 administration. This test reflects the desire of the CSU mathematics and mathematics education community to build a placement test that assesses mathematical skills needed for campus General Education (GE) programs in quantitative reasoning and that serves the needs of entering students planning both quantitative and nonquantitative courses of study. The placement test was developed over a two-year period by a committee of CSU mathematics professors, mathematics education professors, and chairs of mathematics departments.

#### *Content*

The ELM placement test is predicated on the idea that students are responsible for mastering the content of three years of high school mathematics. The test places a major emphasis on working with numbers and data, the connections between algebra and geometry, and problem solving. The test provides the major geometric formulae for reference in support of its purpose to assess understanding of mathematical concepts and problem-solving skills, rather than recall of facts and equations.

Table 1 contains a list of the topics covered by the placement test and shows the proportion of the test devoted to each of the three major content areas: Numbers and Data, Algebra, and Geometry.

#### *Timing*

The ELM placement test contains 50 multiple-choice questions, 45 of which will be scored and 5 of which will be field tested for possible use on future tests. Students will be allotted 90 minutes to complete the test.

#### *Calculators Not Allowed*

Calculators are not allowed for the ELM placement test. The questions on the ELM do not require involved computation. Rather, the placement test includes problems that emphasize quantitative reasoning and problem solving.

You will almost certainly benefit from reviewing for the ELM, especially if you have not taken a math course during the past year. Again, you can refer to the complete list of topics covered by the test on page 15. You can find some sample questions for practice in this Bulletin. You can find more information about the test and more practice questions — 50 of them — in the CSU publication *Focus on Mathematics*, which is available on the web at <http://www.calstate.edu/AR/FOM.pdf>. *Focus* can also be found in your guidance counselor's office and in the test offices and mathematics departments located on all CSU campuses. Another CSU publication, the *ELM Problem Book*, is also available on the web at [http://www.calstate.edu/AR/ELMProblemBook01\\_02.pdf](http://www.calstate.edu/AR/ELMProblemBook01_02.pdf).

## TOPICS ON THE ELM TEST

### NUMBERS AND DATA (approximately 35%)

- ✓ Carry out basic arithmetic calculations
- ✓ Understand and use percent in context
- ✓ Compare and order rational numbers expressed as fractions and/or decimals
- ✓ Solve problems involving fractions and/or decimals in context
- ✓ Interpret and use ratio and proportion in context
- ✓ Use estimation appropriately
- ✓ Evaluate and estimate square roots
- ✓ Represent and understand data presented in tables, pie charts, bar and line graphs, histograms, or other formats for presenting data visually used in print and electronic media)
- ✓ Interpret and calculate the arithmetic mean
- ✓ Interpret and calculate the median
- ✓ Make estimates and predictions based on data

### ALGEBRA (approximately 35%)

- ✓ Evaluate and interpret algebraic expressions
- ✓ Simplify algebraic expressions
- ✓ Express relationships among quantities using variables
- ✓ Use properties of exponents
- ✓ Perform polynomial arithmetic (add, subtract, multiply, divide, and factor)
- ✓ Perform arithmetic operations involving rational expressions
- ✓ Solve linear equations (with both numerical and literal coefficients)
- ✓ Solve systems of linear equations in two unknowns
- ✓ Solve linear inequalities
- ✓ Solve problems in context that are modeled by linear equations
- ✓ Solve quadratic and rational equations (with both numerical and literal coefficients; real solutions only)
- ✓ Solve problems in context that are modeled by quadratic equations
- ✓ Solve equations involving absolute value (in one variable)
- ✓ Solve inequalities involving absolute value (in one variable)
- ✓ Find and use slopes and intercepts of lines
- ✓ Use constant and average rates to solve problems in context (using appropriate units)

### GEOMETRY (approximately 30%)

- ✓ Find the perimeter, area, or volume of geometric figures (including triangles, quadrilaterals, rectangular parallelepipeds, circles, cylinders, and combinations of these figures)
- ✓ Calculate the ratio of corresponding geometric measurements of similar figures (e.g., if the perimeters are in a 3:2 ratio, the areas are in a 9:4 ratio)
- ✓ Use the Pythagorean Theorem
- ✓ Use properties of congruent or similar geometric objects
- ✓ Solve geometric problems using the properties of basic geometric figures (including triangles, quadrilaterals, polygons, and circles)
- ✓ Determine angles in the plane (using properties of intersecting lines, parallel lines, and perpendicular lines)
- ✓ Identify and plot points on the number line
- ✓ Identify and plot points in the coordinate plane
- ✓ Plot points on the graph of a function determined by an algebraic expression
- ✓ Graph linear functions in one variable
- ✓ Graph quadratic functions in one variable
- ✓ Relate basic information about a function to features of its graph (e.g., linearity, positivity or negativity, increasing or decreasing)
- ✓ Find the length or midpoint of a line segment in the coordinate plane

## CALIFORNIA STATE UNIVERSITY ENTRY LEVEL MATHEMATICS TEST

## GEOMETRY REFERENCE FORMULAS

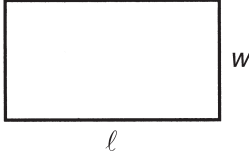
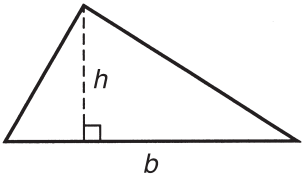
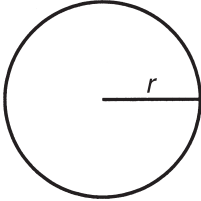
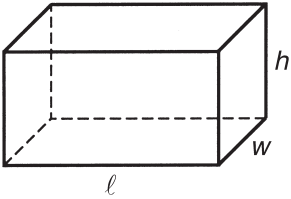
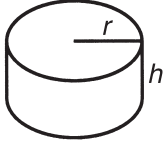
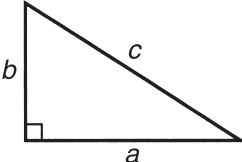
<p>Rectangle</p> 	<p>Area = <math>\ell w</math> Perimeter = <math>2\ell + 2w</math></p>
<p>Triangle</p> 	<p>Area = <math>\frac{1}{2}bh</math></p>
<p>Circle</p> 	<p>Area = <math>\pi r^2</math> Circumference = <math>2\pi r</math></p>
<p>Rectangular Solid</p> 	<p>Volume = <math>\ell wh</math></p>
<p>Right Circular Cylinder</p> 	<p>Volume = <math>\pi r^2 h</math></p>
<p>Pythagorean Theorem</p> 	<p><math>c^2 = a^2 + b^2</math></p>

## ENTRY LEVEL MATHEMATICS EXAMINATION

### SAMPLE PROBLEMS

The following sample questions in the three major content clusters are illustrative of the types of questions that appear on the ELM test. Remember that the actual test will have 50 questions, five of which are included for field-testing purposes and will not count toward your score.

The topic code following each sample question is keyed to the list of topics given on page 15. The answers to the sample questions can be found on page 21.

- Notes:** (1) Unless otherwise specified, the denominators of algebraic expressions appearing in these problems are assumed to be nonzero.
- (2) Figures that accompany problems are drawn as accurately as possible EXCEPT when it is stated that the figure is not drawn to scale.
- (3) The Geometry Reference Formulas appearing on the previous page will be printed inside the front cover of the ELM test book.

1. If  $-3x + 6 = 2x - 9$ , then  $x =$
- (A) 15            (B) 3            (C)  $-\frac{3}{5}$             (D)  $-3$             (E)  $-15$

Topic — Solve Linear Equations

2.

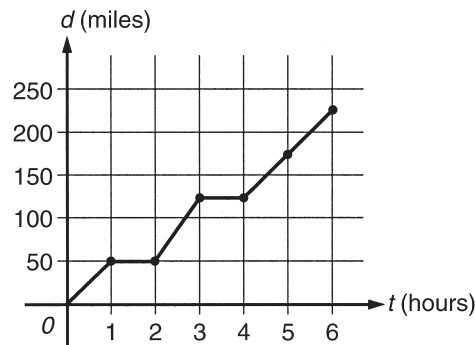

In the graph above,  $d$  represents the distance, in miles, that a motorist has traveled after  $t$  hours on the road. How many hours did it take the motorist to travel 200 miles?

- (A) 4.0            (B) 4.5            (C) 5.0            (D) 5.5            (E) 6.0

Topic — Represent and Understand Data

3. A theater has 25 rows, each with 12 seats. At a certain performance there were, on average, 3 empty seats per row. What was the attendance at that performance?
- (A) 225            (B) 264            (C) 297            (D) 300            (E) 375

Topic — Carry Out Basic Arithmetic Calculations

4.  $\sqrt{64x^{16}} =$
- (A)  $64x^8$             (B)  $32x^8$             (C)  $8x^8$             (D)  $32x^4$             (E)  $8x^4$

Topic — Evaluate Algebraic Expressions

5. What is the area of a circle whose circumference is  $10\pi$  ?
- (A) 5            (B) 25            (C)  $5\pi$             (D)  $25\pi$             (E)  $100\pi$

Topic — Find Area

6. MONTHLY EXPENSES  
OF COMPANY X

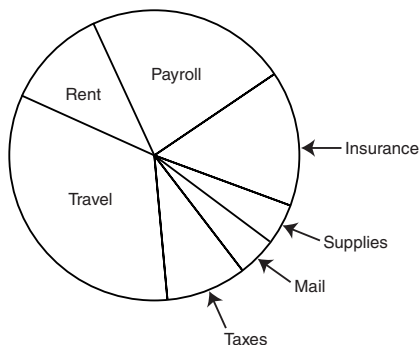

Which of the categories shown in the graph above accounts for approximately one-third of Company X's expenses?

- (A) Insurance    (B) Payroll    (C) Rent    (D) Travel    (E) Taxes

Topic — Represent and Understand Data

7.  $1 - 2x \leq 2 + x$  is equivalent to
- (A)  $x \geq -\frac{1}{3}$     (B)  $x \geq 1$     (C)  $x \leq -\frac{1}{3}$     (D)  $x \leq \frac{1}{3}$     (E)  $x \leq 1$

Topic — Solve Linear Inequalities

8. If the price of a fishing reel that originally sold for \$35 was reduced by 25 percent, what was the reduced price?
- (A) \$28.00    (B) \$26.25    (C) \$17.50    (D) \$8.75    (E) \$7.00

Topic — Use Percent

9. What are all possible values of  $x$  for which  $2x^2 - 4x = 0$ ?
- (A)  $-2$  only    (B)  $0$  only    (C)  $2$  only    (D)  $-2$  and  $2$     (E)  $0$  and  $2$

Topic — Solve Quadratic Equations



What is the perimeter of the figure above if all intersecting line segments meet at right angles?

- (A)  $6x$             (B)  $8x$             (C)  $10x$             (D)  $11x$             (E)  $12x$

Topic — Find Perimeter

11. Five runners in a 100-yard dash ran the race in 13.4, 12.9, 15.0, 12.9, and 14.6 seconds, respectively. What was the average (arithmetic mean) time, in seconds, for runners to complete the race?

(A) 68.80      (B) 17.20      (C) 13.95      (D) 13.76      (E) 13.40

Topic — Calculate the Arithmetic Mean

12.  $\frac{8}{x^2-4} + \frac{6}{3x-6} =$

(A)  $\frac{5}{x-1}$       (B)  $\frac{3}{x^2+3x+2}$       (C)  $\frac{14}{3x^2-12}$       (D)  $\frac{14}{x^2-3x-10}$       (E)  $\frac{2x+12}{x^2-4}$

Topic — Perform Arithmetic Operations Involving Rational Expressions

13. Which of the following numbers is between 3.74 and  $3\frac{4}{5}$ ?

(A)  $3\frac{9}{10}$       (B) 3.72      (C) 3.82      (D)  $3\frac{1}{2}$       (E)  $3\frac{3}{4}$

Topic — Compare and Order Rational Numbers

14.

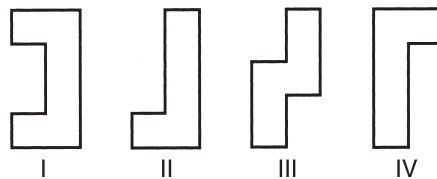

Which of the figures above are congruent?

- (A) I and II  
 (B) I and III  
 (C) I and IV  
 (D) II and III  
 (E) II and IV

Topic — Use Properties of Congruent Geometric Objects

15.  $(a^2b^{-3})^{-2} =$

(A)  $a^2b^6$       (B)  $a^4b^6$       (C)  $(ab)^{12}$       (D)  $\frac{b^6}{a^4}$       (E)  $\frac{1}{b^5}$

Topic — Using Properties of Exponents

16. In the figure to the right,  $CD$  is parallel to  $AB$ . What is the measure of  $\angle ACB$ ?

(A)  $25^\circ$       (B)  $35^\circ$       (C)  $60^\circ$       (D)  $120^\circ$       (E)  $125^\circ$

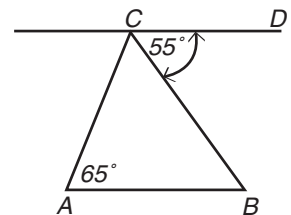

Topic — Determine Angles in the Plane

17. An apple falling from a tree is  $h$  feet above the ground  $t$  seconds after it begins to fall, where  $h = 64 - 16t^2$ . After how many seconds will the apple hit the ground ( $h = 0$ )?

(A) 1            (B) 2            (C) 4            (D) 8            (E) 48

Topic—Solve Problems Modeled by Quadratic Equations

18.

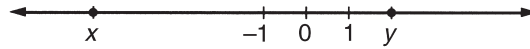

Which of the following must be true about the numbers  $x$  and  $y$  graphed on the number line above?

- I.  $x + y > 0$   
 II.  $y - x > 0$   
 III.  $xy > 0$

(A) I only            (B) II only            (C) III only            (D) II and III only            (E) I, II, and III

Topic—Carry out Basic Arithmetic Calculations

19. This year José earned 3 times as much money as he earned last year. If José earned  $T$  dollars this year and he earned  $L$  dollars last year, which of the following equations represents the relationship between  $T$  and  $L$ ?

(A)  $3L = T$             (B)  $\frac{L}{3} = T$             (C)  $T \times L = 3$             (D)  $\frac{L}{3} = \frac{T}{3}$             (E)  $\frac{L}{3} = \frac{3}{T}$

Topic—Express Relationships Among Quantities

20.

ANNUAL COST OF WATER PER HOUSEHOLD IN 5 COMMUNITIES

Ashville	\$696
Buckview	\$557
Centerville	\$268
Deerfield	\$156
Elmwood	\$434

What is the median annual cost of water per household in the 5 communities listed in the table above?

(A) \$156            (B) \$268            (C) \$434            (D) \$557            (E) \$696

Topic — Calculate the Median

21. Three spheres, each 2 inches in diameter, fit exactly inside the cylindrical can in the figure to the right. The volume of the can, in cubic inches, is

(A)  $3\pi$   
 (B)  $4\pi$   
 (C)  $6\pi$   
 (D)  $12\pi$   
 (E)  $24\pi$

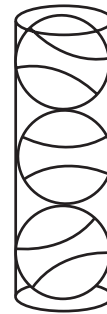

Topic — Find Volume

22. Which of the following is an equation of a line that is parallel to the line with equation  $2y + 4x = 3$ ?

(A)  $y + 2x = 3$             (B)  $y - 2x = 3$             (C)  $2y - 4x = 3$             (D)  $-2y + 4x = 3$             (E)  $4y + 2x = 3$

Topic — Find and Use Slopes of Lines

23. An investment company advertised that last year its clients, on average, made a profit of 9%. Which of the following claims can legitimately be made, based on that information?
- (A) All of their clients made a profit of at least 9% last year.  
 (B) At least one of their clients made a profit of at least 9% last year.  
 (C) Some of their clients will make a profit of at least 9% this year.  
 (D) All of their clients will make a profit of at least 9% this year.  
 (E) If a person becomes one of their clients, that person will make a profit of at least 9% each year.

Topic—Understand Percent in Context

24.

WEATHER BALLOON TEMPERATURES

Height	Temperature
1,000 ft.	23°
2,000 ft.	20°
3,000 ft.	17°

A weather balloon is released and as it rises in the air it records the temperature, in degrees Celsius, as shown in the table above. If the temperature continues to decrease at a constant rate, the temperature at 5,500 feet will be

- (A) 12.5°      (B) 11°      (C) 9.5°      (D) 8°      (E) 6.5°

Topic—Use Constant Rates

25. In the coordinate plane, which of the following is the midpoint of the line segment with endpoints (2,5) and (6,1)?

- (A) (8,6)      (B) (4,3)      (C) (4,4)      (D)  $\left(\frac{7}{2}, \frac{7}{2}\right)$       (E)  $\left(\frac{3}{2}, \frac{5}{2}\right)$

Topic — Find the Midpoint of a Line Segment

**Answers to Sample ELM Questions**

<b>1. B</b>	<b>6. D</b>	<b>11. D</b>	<b>16. C</b>	<b>21. C</b>
<b>2. D</b>	<b>7. A</b>	<b>12. E</b>	<b>17. B</b>	<b>22. A</b>
<b>3. A</b>	<b>8. B</b>	<b>13. E</b>	<b>18. B</b>	<b>23. B</b>
<b>4. C</b>	<b>9. E</b>	<b>14. E</b>	<b>19. A</b>	<b>24. C</b>
<b>5. D</b>	<b>10. E</b>	<b>15. D</b>	<b>20. C</b>	<b>25. B</b>

## CSU REGISTRATION AND TESTING CENTERS

Send EPT/ELM registration materials to: **University Name and Address (listed below), Attn.: Testing Office** The campus Testing Office will send you an admission ticket one or two weeks before the test. The time(s) and location(s) of the test administration(s) will be provided on the admission ticket. See the back of the registration form for detailed information.

### CSU, Bakersfield

Test Center  
9001 Stockdale Highway  
Bakersfield, CA 93311-1099  
www.csub.edu  
(661) 664-3373 FAX (661) 665-6916

### CSU, Channel Islands

Student Life  
Bell Tower 1769  
One University Drive  
Camarillo, Ca 93012  
www.csuci.edu  
E-mail: student.life@csuci.edu  
(805) 437-8400 FAX (805) 437-8529

### CSU, Chico

Testing & Research  
MLIB 143  
Chico, CA 95929-0704  
www.csuchico.edu/test  
(530) 898-6218 FAX (530) 898-4611

### CSU, Dominguez Hills

Testing Office, Welch Hall 210  
1000 East Victoria Street  
Carson, CA 90747  
www.csudh.edu/air/testing/index.htm  
E-mail: testing@research.csudh.edu  
(310) 243-3909 FAX (310) 516-3330

### CSU, East Bay

Testing Office – WA400  
25800 Carlos Bee Blvd.  
Hayward, CA 94542  
www.testing.csueastbay.edu  
(510) 885-3661 FAX (510) 885-4242

### CSU, Fresno

Office of Testing Services  
Family and Food Sciences Bldg.  
Room 110  
5300 N. Campus Dr.  
Fresno, CA 93740-8019  
www.csufresno.edu/testing  
(559) 278-2457 FAX (559) 278-3583

### CSU, Fullerton

Testing Services  
P.O. Box 6830  
Fullerton, CA 92834-6830  
www.fullerton.edu/testing  
E-mail: testingcenter@fullerton.edu  
(714) 278-3838 FAX (714) 278-4834

### Humboldt State University

Testing Center  
Arcata, CA 95521-8299  
http://studentaffairs.humboldt.edu/testing  
(707) 826-3611 FAX (707) 826-5663

### CSU, Long Beach

Testing & Evaluation Services  
1250 Bellflower Blvd. BH 216  
Long Beach, CA 90840-0110  
www.csulb.edu/divisions/student2/Testing-Evaluation  
(562) 985-4007 FAX (562) 985-2415

### CSU, Los Angeles

Testing Center  
5151 State University Drive  
JFK Library, Palmer Wing  
Los Angeles, CA 90032  
www.calstatela.edu/centers/testctr  
E-mail: testctr@calstatela.edu  
(323) 343-3460 FAX (323) 343-5051

### California Maritime Academy

Office of Admissions  
200 Maritime Academy Dr.  
Vallejo, CA 94590  
www.csum.edu  
E-mail: admission@csum.edu  
(707) 654-1330 FAX (707) 654-1017

### CSU, Monterey

100 Campus Center, Bldg. 47  
Seaside, CA 93955-8001  
www.csumb.edu/student/services/testing  
E-mail: Admissions@csumb.edu  
(831) 582-3738

### CSU, Northridge

Testing Center  
18111 Nordhoff Street  
Northridge, CA 91330-8240  
www.csun.edu  
E-mail: testing.center@csun.edu  
(818) 677-2369 FAX (818) 677-5886

### Cal Poly Pomona

Testing Center  
3801 W. Temple Avenue  
Pomona, CA 91768-4002  
www.csupomona.edu/~academic/testcenter  
(909) 869-3353 FAX (909) 869-2899

### CSU, Sacramento

6000 J Street, Lassen Hall 2302  
Sacramento, CA 95819-6058  
www.csus.edu/testing  
(916) 278-6296 FAX (916) 278-7867

### CSU, San Bernardino

Testing Office – JB 405  
5500 University Parkway  
San Bernardino, CA 92407  
www.csusb.edu  
(909) 537-5045 FAX (909) 5377187

### San Diego State University

5500 Campanile Drive, SS-2549  
San Diego, CA 92182-7449  
www.sdsu.edu/testoffice  
(619) 594-5216

### San Francisco State University

1600 Holloway Avenue, HSS 206  
San Francisco, CA 94132-4154  
www.sfsu.edu/~testing  
E-mail: testing@sfsu.edu  
(415) 338-2271 FAX (415) 338-0589

### San Jose State University

Testing & Systems  
One Washington Square  
San Jose, CA 95192-0039  
www.sjsu.edu/testing  
E-mail: testeval@sjsu.edu  
(408) 924-5980

### Cal Poly San Luis Obispo

Testing Services 124-121  
San Luis Obispo, CA 93407  
www.testoffice.calpoly.edu  
E-mail: testing@calpoly.edu  
(805) 756-1551 FAX (805) 756-5340

### CSU, San Marcos

Attn: Test Officer  
Career & Transfer Student Services  
San Marcos, CA 92096-0001  
www.csusm.edu/careers  
(760) 750-4900 FAX (760) 750-3142

### Sonoma State University

Testing Services  
Salazar Hall #1070  
1801 E. Cotati Avenue  
Rohnert Park, CA 94928  
www.sonoma.edu/sas/testing  
(707) 664-2947 FAX (707) 664-4016

### CSU, Stanislaus

Testing Office  
801 West Monte Vista Ave-MSR 180  
Turlock, CA 95382  
www.csustan.edu/counseling/testing  
E-mail: testing\_office@csustan.edu  
(209) 667-3157

## TEST DATES

CAMPUS	TEST DATE	REG. DEADLINE	STUDENTS RECEIVE SCORES LATE IN WEEK OF...	CAMPUS	TEST DATE	REG. DEADLINE	STUDENTS RECEIVE SCORES LATE IN WEEK OF...
<b>BAKERSFIELD</b> www.csusb.edu On-line registration available	1/7/06	12/30/05	2/6/06	<b>FRESNO</b> www.csufresno.edu/testing On-line registration available. See campus website for additional testing dates.	*3/18/06	3/3/06	4/10/06
	*3/18/06	3/3/06	4/10/06		*5/6/06	4/21/06	5/29/06
	4/15/06	3/31/06	5/29/06		*6/17/06	6/2/06	7/10/06
	*5/6/06	4/21/06	5/29/06		*3/17/07	3/2/07	4/9/07
	*6/17/06	6/2/06	7/10/06		*5/5/07	4/20/07	5/28/07
	9/6/06	8/23/06	11/13/06		*6/16/07	6/1/07	7/9/07
	1/6/07	12/29/06	2/5/07				
	*3/17/07	3/2/07	4/9/07				
	*5/5/07	4/20/07	5/28/07				
	*6/16/07	6/1/07	7/9/07				
<b>CHANNEL ISLANDS</b> www.csuci.edu	*3/18/06	3/3/06	4/10/06	<b>FULLERTON</b> www.fullerton.edu/testing On-line registration available.	12/3/05	11/18/05	1/2/06
	4/15/06	3/31/06	5/29/06		*3/18/06	3/3/06	4/10/06
	*5/6/06	4/21/06	5/29/06		4/1/06	3/17/06	5/29/06
	*6/17/06	6/2/06	7/10/06		*5/6/06	4/21/06	5/29/06
	*3/17/07	3/2/07	4/9/07		*6/17/06	6/2/06	7/10/06
	*5/5/07	4/20/07	5/28/07		7/22/06	7/7/06	8/14/06
	*6/16/07	6/1/07	7/9/07		12/2/06	11/17/06	12/25/06
					*3/17/07	3/2/07	4/9/07
					*5/5/07	4/20/07	5/28/07
					*6/16/07	6/1/07	7/9/07
<b>CHICO</b> www.csuchico.edu/test	*3/18/06	3/3/06	4/10/06	<b>HUMBOLDT</b> http://studentaffairs.humboldt.edu/testing/ On-line registration available.	*3/18/06	3/3/06	4/10/06
	*5/6/06	4/21/06	5/29/06		*5/6/06	4/21/06	5/29/06
	*6/17/06	6/2/06	7/10/06		*6/17/06	6/2/06	7/10/06
	11/4/06	10/20/06	12/4/06		*3/17/07	3/2/07	4/9/07
	*3/17/07	3/2/07	4/9/07		*5/5/07	4/20/07	5/28/07
	*5/5/07	4/20/07	5/28/07		*6/16/07	6/1/07	7/9/07
	*6/16/07	6/1/07	7/9/07				
<b>DOMINGUEZ HILLS</b> www.csudh.edu/air/testing/index.htm	12/3/05	11/18/05	1/2/06	<b>LONG BEACH</b> www.csulb.edu/divisions/students/2/departments/testing-Evaluation/index.htm	12/3/05	11/18/05	1/2/06
	1/14/06	1/2/06	2/6/06		1/14/06	1/6/06	2/6/06
	2/18/06	2/3/06	3/13/06		*3/18/06	3/3/06	4/10/06
	*3/18/06	3/3/06	4/10/06		*5/6/06	4/21/06	5/29/06
	*5/6/06	4/21/06	5/29/06		*6/17/06	6/2/06	7/10/06
	*6/17/06	6/2/06	7/10/06		7/15/06	6/30/06	8/14/06
	7/22/06	7/7/06	8/14/06		8/19/06	8/4/06	9/11/06
	8/19/06	8/4/06	9/11/06		12/2/06	11/17/06	12/25/06
	10/21/06	10/6/06	11/13/06		*3/17/07	3/2/07	4/9/07
	12/2/06	11/17/06	12/25/06		*5/5/07	4/20/07	5/28/07
	1/13/07	12/22/06	2/5/07		*6/16/07	6/1/07	7/9/07
	2/17/07	2/2/07	3/12/07				
	*3/17/07	3/2/07	4/9/07				
	*5/5/07	4/20/07	5/28/07				
	*6/16/07	6/1/07	7/9/07				
<b>EAST BAY</b> www.testing.csueastbay.edu On-line registration available.	12/3/05	11/18/05	1/2/06	<b>LOS ANGELES</b> www.calstateia.edu/centers/testing	12/3/05	11/19/05	1/2/06
	1/7/06	12/14/05	2/6/06		1/14/06	12/31/05	2/6/06
	*3/18/06	3/3/06	4/10/06		2/18/06	2/4/06	3/13/06
	4/1/06	3/17/06	5/29/06		*3/18/06	3/3/06	4/10/06
	*5/6/06	4/21/06	5/29/06		*5/6/06	4/21/06	5/29/06
	*6/17/06	6/2/06	7/10/06		*6/17/06	6/2/06	7/10/06
	6/24/06	6/9/06	8/14/06		7/22/06	7/8/06	8/14/06
	8/12/06	7/28/06	9/11/06		8/12/06	7/29/06	9/11/06
	9/23/06	9/8/06	11/13/06		9/16/06	9/2/06	11/13/06
	10/28/06	10/13/06	12/04/06		10/28/06	10/2/06	12/4/06
	12/09/06	11/24/06	2/5/07		1/6/07	12/23/06	2/5/07
	*3/17/07	3/2/07	4/9/07		*3/17/07	3/2/07	4/9/07
	*5/5/07	4/20/07	5/28/07		*5/5/07	4/20/07	5/28/07
	*6/16/07	6/1/07	7/9/07		*6/16/07	6/1/07	7/9/07

## TEST DATES

CAMPUS	TEST DATE	REG. DEADLINE	STUDENTS RECEIVE SCORES LATE IN WEEK OF...	CAMPUS	TEST DATE	REG. DEADLINE	STUDENTS RECEIVE SCORES LATE IN WEEK OF...
<b>MARITIME ACADEMY</b> www.csun.edu	*3/18/06	3/3/06	4/10/06	<b>SAN BERNARDINO</b> www.csusb.edu	1/7/06	12/16/05	2/6/06
	*5/6/06	4/21/06	5/29/06		*3/18/06	3/3/06	4/10/06
	*6/17/06	6/2/06	7/10/06		4/8/06	3/24/06	5/29/06
	*3/17/07	3/2/07	4/9/07		*5/6/06	4/21/06	5/29/06
	*5/5/07	4/20/07	5/28/07		6/24/06	6/9/06	8/14/06
	*6/16/07	6/1/07	7/9/07		7/29/06	7/14/06	9/11/06
					8/26/06	8/11/06	11/13/06
			9/16/06	9/1/06	11/13/06		
			11/11/06	10/27/06	12/4/06		
			1/6/07	12/15/06	2/5/07		
			*3/17/07	3/2/07	4/9/07		
			*5/5/07	4/20/07	5/28/07		
			*6/16/07	6/1/07	7/9/07		
<b>MONTEREY BAY</b> www.csUMB.edu/student/services/testing On-line registration available.	*3/18/06	3/3/06	4/10/06	<b>SAN DIEGO</b> www.sdsu.edu/testoffice On-line registration available.	1/28/06	1/13/06	3/13/06
	*5/6/06	4/21/06	5/29/06		*3/18/06	3/3/06	4/10/06
	*6/17/06	6/2/06	7/10/06		4/1/06	3/17/06	5/29/06
	*3/17/07	3/2/07	4/9/07		4/15/06	3/31/07	5/29/06
	*5/5/07	4/20/07	5/28/07		*5/6/06	4/21/06	5/29/06
	*6/16/07	6/1/07	7/9/07		*6/17/06	6/2/06	7/10/06
					*3/17/07	3/2/07	4/9/07
			*5/5/07	4/20/07	5/28/07		
			*6/16/07	6/1/07	7/9/07		
<b>NORTHRIDGE</b> www.csun.edu	*3/18/06	3/3/06	4/10/06	<b>SAN FRANCISCO</b> www.sfsu.edu/~testing On-line registration available. Check website for additional testing dates	*3/18/06	3/3/06	4/10/06
	*5/6/06	4/21/06	5/29/06		*5/6/06	4/21/06	5/29/06
	*6/17/06	6/2/06	7/10/06		*6/17/06	6/2/06	7/10/06
	10/7/06	9/22/06	11/13/06		*3/17/07	3/2/07	4/9/07
	11/11/06	10/27/06	12/4/06		*5/5/07	4/20/07	5/28/07
	*3/17/07	3/2/07	4/9/07		*6/16/07	6/1/07	7/9/07
	*5/5/07	4/20/07	5/28/07				
*6/16/07	6/1/07	7/9/07					
<b>POMONA</b> www.csupomona.edu/~academic/testcenter On-line registration available.	2/25/06	2/10/06	4/10/06	<b>SAN JOSE</b> www.sjsu.edu/testing On-line registration available.	2/18/06	2/3/06	3/13/06
	*3/18/06	3/3/06	4/10/06		*3/18/06	3/3/06	4/10/06
	*5/6/06	4/21/06	5/29/06		4/8/06	3/24/06	5/29/06
	*6/17/06	6/2/06	7/10/06		*5/6/06	4/21/06	5/29/06
	7/15/06	6/30/06	8/14/06		*6/17/06	6/2/06	7/10/06
	8/19/06	8/4/06	9/11/06		10/14/06	9/29/06	11/13/06
	10/21/06	10/6/06	11/13/06		11/11/06	10/27/06	12/4/06
*3/17/07	3/2/07	4/9/07	*3/17/07	3/2/07	4/9/07		
*5/5/07	4/20/07	5/28/07	*5/5/07	4/20/07	5/28/07		
*6/16/07	6/1/07	7/9/07	*6/16/07	6/1/07	7/9/07		
<b>SACRAMENTO</b> www.csus.edu/testing On-line registration available.	1/14/06	12/30/05	2/6/06	<b>SAN LUIS OBISPO</b> www.testoffice.calpoly.edu On-line registration available.	1/7/06	12/19/05	2/6/06
	2/25/06	2/10/06	4/10/06		*3/18/06	3/3/06	4/10/06
	*3/18/06	3/3/06	4/10/06		*5/6/06	4/21/06	5/29/06
	4/8/06	3/24/06	5/29/06		*6/17/06	6/2/06	7/10/06
	*5/6/06	4/21/06	5/29/06		7/22/06	7/7/06	8/14/06
	5/20/06	5/5/06	7/10/06		9/23/06	9/8/06	11/13/06
	*6/17/06	6/2/06	7/10/06		10/21/06	10/6/06	11/13/06
7/15/06	6/30/06	8/14/06	1/13/07	12/15/06	2/5/07		
8/26/06	8/11/06	11/13/06	*3/17/07	3/2/07	4/9/07		
11/18/06	11/3/06	12/25/06	*5/5/07	4/20/07	5/28/07		
*3/17/07	3/20/07	4/9/07	*6/16/07	6/1/07	7/9/07		
*5/5/07	4/20/07	5/28/07					
*6/16/07	6/1/07	7/9/07					

\* All CSU campuses give both EPT and ELM on these dates. The other dates are subject to change, so be sure to check the appropriate Testing Office website (or telephone the Office) before you register to test on one of these dates.

## TEST DATES

CAMPUS	TEST DATE	REG. DEADLINE	STUDENTS RECEIVE SCORES LATE IN WEEK OF...	CAMPUS	TEST DATE	REG. DEADLINE	STUDENTS RECEIVE SCORES LATE IN WEEK OF...
<b>SAN MARCOS</b> <a href="http://www.csusm.edu/catss">www.csusm.edu/catss</a> On-line registration available.				<b>STANISLAUS</b> <a href="http://www.csustan.edu/counseling/testing">www.csustan.edu/counseling/testing</a> Downloadable registration form available.			
	*3/18/06	3/3/06	4/10/06		1/7/06	12/9/05	2/6/06
	*5/6/06	4/21/06	5/29/06		*3/18/06	3/3/06	4/10/06
	*6/17/06	6/2/06	7/10/06		*5/6/06	4/21/06	5/29/06
	*3/17/07	3/2/07	4/9/07		*6/17/06	6/2/06	7/10/06
	*5/5/07	4/20/07	5/28/07		7/22/06	7/7/06	8/14/06
	*6/16/07	6/1/07	7/9/07		11/14/06	10/20/06	12/4/06
<b>SONOMA</b> <a href="http://www.sonoma.edu/sas/testing">www.sonoma.edu/sas/testing</a> Registration must be done on-line							
	12/3/05	11/21/05	1/2/06				
	1/28/06	1/16/06	3/13/06				
	*3/18/06	3/6/06	4/10/06				
	4/8/06	3/24/06	5/29/06				
	*5/6/06	4/24/06	5/29/06				
	*6/17/06	6/5/06	7/10/06				
	8/19/06	8/7/06	9/11/06				
	10/14/06	10/2/06	11/13/06				
	12/2/06	11/20/06	12/25/06				
	*3/17/07	3/2/07	4/9/07				
	*5/5/07	4/20/07	5/28/07				
	*6/19/07	6/1/07	7/9/07				

\* All CSU campuses give both EPT and ELM on these dates. The other dates are subject to change, so be sure to check the appropriate Testing Office website (or telephone the Office) before you register to test on one of these dates.